

SIENNA[®] SYSTEM

Switch to the future

Home control

ingeniously simple

Energy efficiency

Security

Lifestyle



SIENNA® SYSTEM

the new dimension in home automation

Ingeniously simple!!

- Easy to install and easy to reconfigure.
- Installation and configuration can be done with a screwdriver!
- No need for a PC or special software.
- Can be combined with all commercially available switches and power outlets.
- Can be retrofitted in all existing buildings.
- Simplifies wiring and eliminates detailed wiring plans.
- No additional cables or electromagnetic smog.
- Extremely reliable due to usage of LON technology.

Simply ingenious !!



The **SIENNA®** elements form a bus system consisting of sensors and actuators which use the in-house power lines as a communication bus. The **SIENNA®** system revolutionizes wiring plans and places the intelligence of the system into smart elements, located wherever they are needed in a home or a building.

The extremely simple installation process makes **SIENNA®** the ideal system not only for new buildings but also for renovations and retrofitting. No computers, no software, no special training is required -- all you need is a screwdriver and you can install and configure the system.

| | |
|---|--|
| Switching a single channel | 4 |
| SM1L / SM1B | Sensor with one digital 230V input |
| SM1 | Sensor with one digital input |
| AM1 | Actuator with one switched output |
| AM1C | Actuator with one switched output with current measurement |
| Switching multiple channels | 6 |
| SM2 | Sensor with two digital inputs |
| SM2G | Sensor with two digital inputs for switching multiple groups |
| AM2L / AM2X | Actuator with two switched outputs |
| SM4 / SM8 | Sensor with digital inputs for 4 to 8 channels |
| Switching with auxiliary functions | 8 |
| SAM1L | Sensor-Actuator with one switched output and one 230V input |
| SAM2L | 2-Channel switch actuator with inputs |
| SAM1LT | Sensor-Actuator with timer for delayed switching |
| SM1L+R | Sensor with actuator-status display |
| Motor control | 10 |
| SM3 | Sensor with three digital inputs for motor control |
| SM3G | Sensor with three digital inputs for controlling motors in multiple groups |
| AM2 / AMX2 | Actuator with two interlocked outputs for motor control |
| SAM2 | Sensor-Actuator for motor control |
| Dimmer / Toggle Actuators | 12 |
| AMDR | Actuator with one Triac output for dimming (Leading edge) |
| SAMDR | Sensor-Actuator with one input for dimming (Leading edge) |
| AMD10V | Actuator with 1-10V interface for dimming |
| AM1A / AMXA | Toggle actuator with two oppositely switched outputs |
| Home Automation | 14 |
| SIENNA® Home | Controller for home automation and remote access |
| SMPTEMP / SAMTEMP | Thermostat |
| RFGS | Wireless gateway inc. wireless remote for all SIENNA® actuators |
| Configuration | 16 |
| SIENNA® Professional | Configuration software for SIENNA® modules. |
| Accessories | 17 |
| Technical Data | 17 |
| Address assignment | 18 |
| Applications | 19 |
| FAQ | 23 |

Switching single channels

SIENNA[®] SYSTEM

Switch to the future

SM1L / SM1B



SM1L-ST01-H02 / SM1B-ST04-H02
EAN-Number: 4260194732019 / 101

SENSOR with 230V input

The **SIENNA[®] SM1L** sensor has one 230V input. The input can be connected to a light switch or other switching elements (e.g. motion detector, thermostat etc..). For optimized wiring, L, N can be extended via the additional terminals L', N.

Operational Modes:

Push (Each push triggers a switching action); On / Off; 3-Way.

Input:

One digital input (L, 1) with 230V / ~50Hz (Phase bridged to L'). Can also be used with switches that have an integrated status lamp.

SIENNA[®] SM1B for motion- detectors with continuous operation feature (Continuous on; Continuous off).

SM1



SM1-ST06-H02
EAN-Number: 4260194732002

SENSOR with 5V (internal) input

The **SIENNA[®] SM1** sensor has one 5V input which can be connected to a switch (On/Off, Off / On) or a push switch (dimmers & motors). Connection to magnetic contacts or 0,08mm² cables is also possible with the internal 5V input.

Potential free switching elements are required!

Operational Modes:

Push (Each push triggers a switching action); On / Off; Off / On.

Input:

One digital input (0, 1) for connecting to a switch, push switch or magnetic contact. 5V Input can also be used with 0,08mm² connector cables. Max. cable length to switch: 10m.

AM1



AM1-ST01-H01
EAN-Number: 4260194730008

ACTUATOR for On / Off switching

The **SIENNA[®] AM1** actuator can either be directly attached to an electrical device or flush-mounted behind a power outlet. The **SIENNA[®] AM1** actuator has one relay-switched output for electrical devices with current ratings up to 10A.

Output:

L', N for connecting the electrical device. One single-pole relay rated at 10A to switch L'.

N is bridged to the neutral of the power supply.

AM1C



AM1C-ST01-H01
EAN-Number: 4260194730039

ACTUATOR for On / Off switching with current measurement

Similar to the **SIENNA[®] AM1** actuator but with additional current measurement capability.

Visualization and recording of current usage with **SIENNA[®] Professional**.

Switching single channels

Controlling a remote device from multiple points

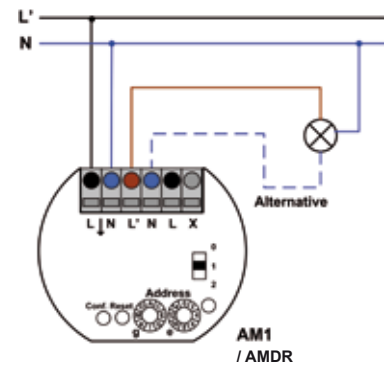
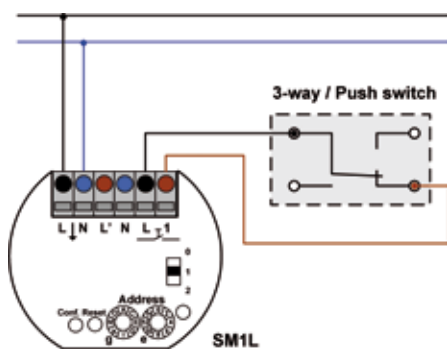
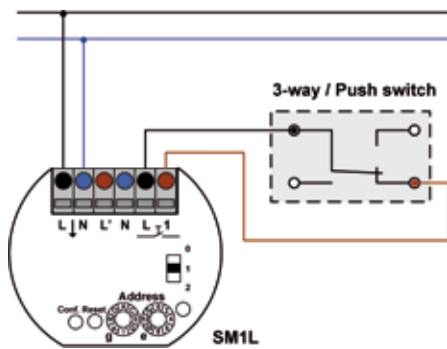

Controlling an additional device

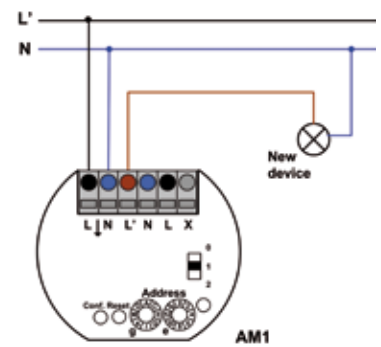
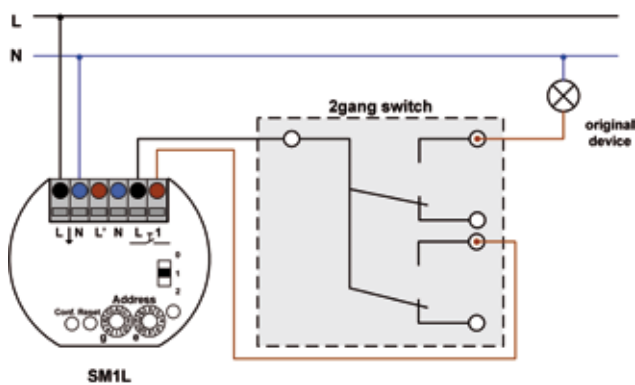

Enable an exhaust fan via magnetic contact connected to sensor

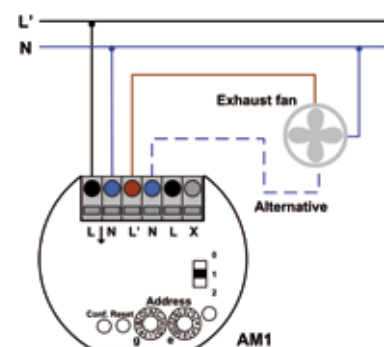
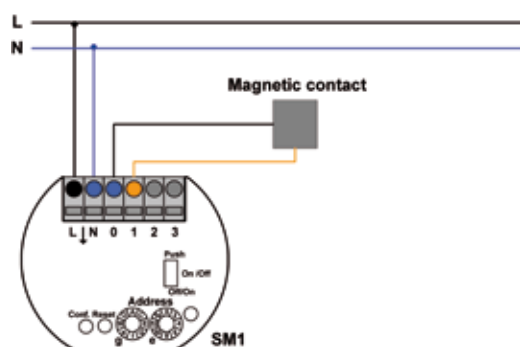

Switching multiple channels

SIENNA® SYSTEM

Switch to the future

SM2



SM2-ST05-H02
EAN-Number: 4260194732026

SENSOR with two digital inputs

The **SIENNA® SM2** sensor has two digital inputs (internal 5V) which can be connected to one 2-gang switch or to two separate switches. This sensor switches 2 actuators with addresses (g, e) and (g, e +1).

Potential free switching elements required!

Operational Modes:

Push (each push triggers a switching action); On / Off; Off / On;

Input:

Two digital (internal 5V) inputs (0, 1, 2) connecting to a 2-gang switch or to 2 switches.

SM2G



SM2G-ST011-H02
EAN-Number: 4260194732057

SENSOR with digital inputs for switching multiple groups

The **SIENNA® SM2G** sensor has two digital inputs (internal 5V) which can be connected to one 2-gang switch or to two separate switches. This sensor switches 2 groups (g, e) and (g + 1, e).

Potential free switching elements required!

Operational Modes:

Push (each push triggers a switching action); On / Off; Off / On;

Input:

Two digital (internal 5V) inputs (0, 1, 2) connecting to a 2-gang switch or to 2 switches.

AM2L / AM2X



AM2L-ST02-H01 / AM2X-ST06-H01
EAN-Number: 4260194730060 / 107

ACTUATOR with two outputs

The **SIENNA® AM2L** actuator can either be directly attached to an electrical device or flush-mounted and is designed for switching two separate devices or electrical circuits. **AM2L** has two relay-switched output for loads up to 5A.

Output:

L1, N, L2, N to the devices / electrical circuits: one relay each to switch up to 5A on L1, L2.

The output terminals N are bridged to the neutral of the power supply.

The SIENNA® AM2X actuator is similar to **AM2L**, but has potential free outputs.

SM4 / SM8

Available Sept. 2010

SM4-ST01-H01 / SM8-ST02-H01
EAN-Number: 4260194732118 / 25

SENSOR with digital inputs for 4 to 8 channels

The **SIENNA® SM4** Sensor has four digital inputs (internal 5V) which can be connected to multiple switches. **This sensor can switch up to 4 different actuators.**

Operational Modes:

Push (each push triggers a switching action); On / Off; Off / On;

Input:

Four digital (internal 5V) inputs (0, 1, 2, 3, 4) with flexible connecting wires which can be connected to a single multiple-gang switch or to four separate switches.

SIENNA® SM8 sensor is similar to **SM4**, but has 8 digital inputs for 8 channels.

Switching multiple channels

Combining 1-channel and 2-channel modules:

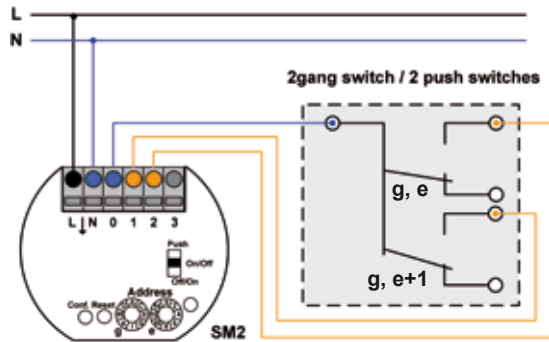

Address assignment: g, e

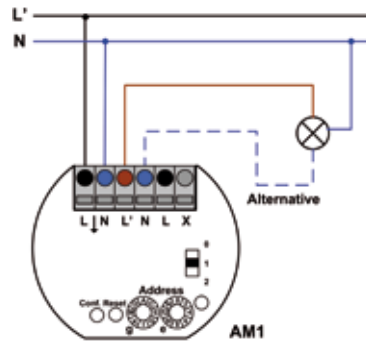

Address assignment: g, e

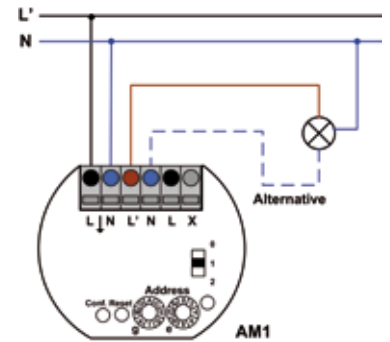

Address assignment: g, e + 1

Sensor (2-channel) switches 2-channel actuators and / or 1-channel actuators.

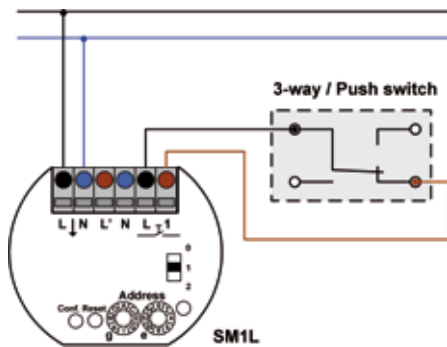

Address assignment: g, e

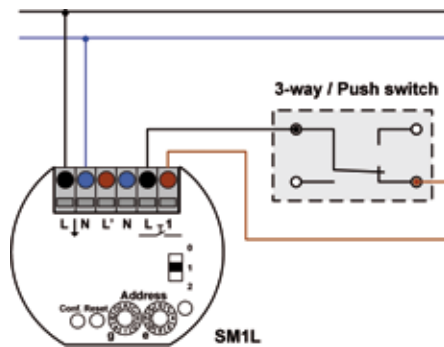

Address assignment: g, e + 1

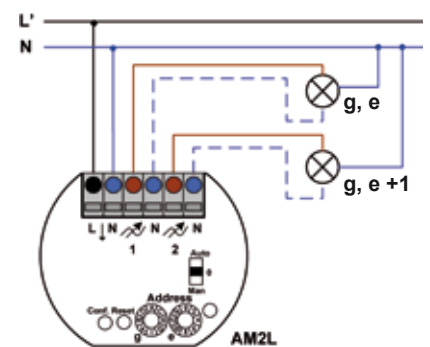

Controlled via 1 sensor (2-channel) and / or 2 sensors (1-channel).

Carrying forward a 3-Way contact

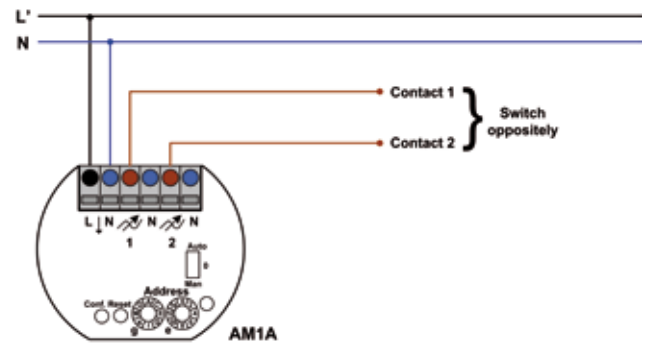
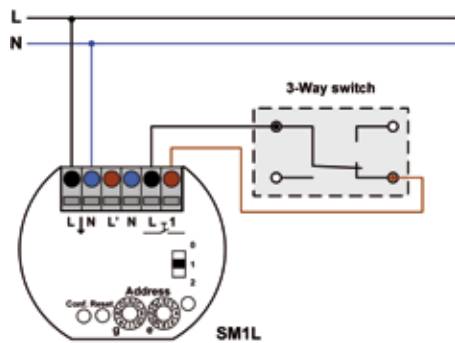

SAM1L



SAM1L-ST01-H01
EAN-Number: 4260194734006

SENSOR / ACTUATOR combination

SIENNA® SAM1L combines the **SM1L** sensor and **AM1** actuator. **SAM1L** has one 230V input and one switched output for loads up to 10A. The input can be connected to a light switch or to other switching elements (e.g. motion detector, thermostat etc..).

Operational modes:

Push (each push triggers a switching action), On / Off; 3-Way.

Input:

One digital input (L, 1) with 230V / ~50Hz. Can also be used with illuminated switches.

Output:

L', N connected to electrical device; One relay rated at 10A to switch L'. N is bridged to the neutral of the power supply.

SAM2L



SAM2L-ST03-H01
EAN-Number: 4260194734051

SENSOR / ACTUATOR combination with 2 channels

SIENNA® SAM2L has two relay-switched outputs for switching 2 separate devices with current ratings up to 5A. The inputs with flexible wires can be directly connected to a 2-gang switch.

Operational modes:

Push (each push triggers a switching action), On / Off; 3-Way.

Input:

Three flexible wires for connecting to a switch.

Output:

Output terminals ▲ and ▼ for connecting to devices 1 and 2. N is bridged to the neutral of the power supply

SAM1LT



SAM1LT-ST03-H01
EAN-Number: 4260194734013

SENSOR / ACTUATOR combination with timer

SIENNA® SAM1LT includes a time-delayed switching functionality in addition to the **SAM1L** module (e.g. for hallway lighting). Delay time can be set within a range of 1 Min. to 2 Hrs.

Operational modes:

Push (each push triggers a switching action), On / Off; 3-Way.

Input:

One digital input (L, 1) with 230V / ~50Hz (Phase bridged to L'). Can also be used with illuminated switches.

Output:

L', N connected to electrical device; One relay rated at 10A to switch L'. N is bridged to the neutral of the power supply.

SM1L+R



SM1LR-ST02-H01
EAN-Number: 4260194732095

SENSOR with actuator status display

The **SIENNA® SM1L+R** sensor has one 230V input like SM1L. One switched 230V output (max. 1A) indicates the status of the corresponding actuator.

Operational modes:

Push (each push triggers a switching action), On / Off; 3-Way.

Input:

One digital input (L, 1) with 230V / ~50Hz (Phase bridged to L'). Can also be used with illuminated switches.

Output:

Switched 230V output (L', N) for displaying actuator status. N is bridged to the neutral of the power supply.

Switching with auxiliary functions

Additional control point for a device

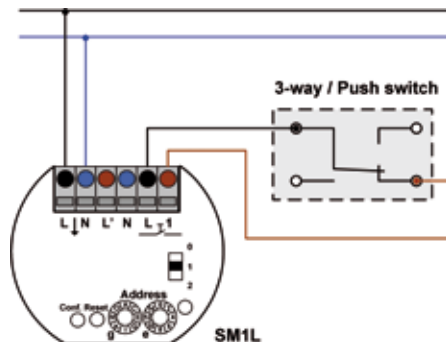
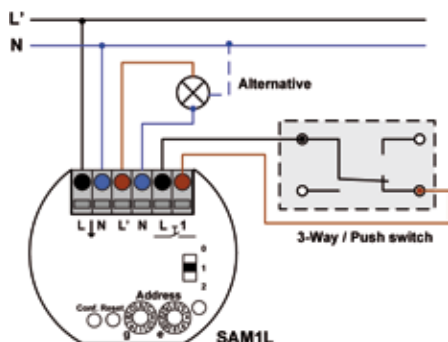

Delayed switching (hallway lighting)

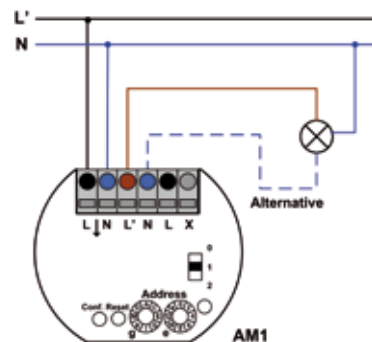
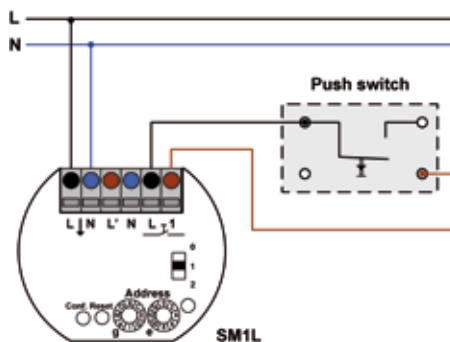
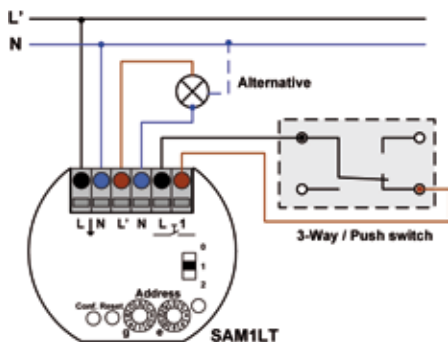

SAM1LT switches OFF all actuators after a preset time interval.

Displaying actuator status via sensor

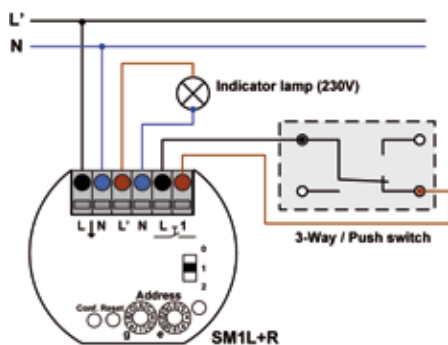

← Display actuator status

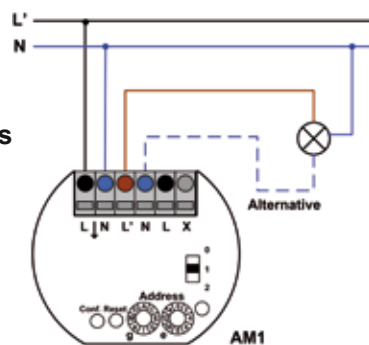

Output of sensor SM1L+R switches depending on actuator feedback and displays the actuator status.

SM3



SM3-ST02-H02
EAN-Number: 4260194732064

SENSOR with three digital inputs

The **SIENNA® SM3** sensor has three digital inputs which can be connected to a 2-gang or 3-gang switch (Blind, Shutter: Up, Down, Stop). Centralized switching functionality (Master-On, Master-Off) can also be implemented with **SM3**. Potential free switching elements required!

Input:

Three binary (internal 5V) inputs (0, 1, 2, 3).

0: Common ground

1 / 2: Up (Master switch: On) / Down (Master switch: Off)

3: as defined by operational mode

Operational mode for input 3 (sliding switch):

Aus/Ein: Go up and stay blocked as long as input 3 is active (e.g. wind sensor).

Ein /Aus: Biased-off switch independent of actuator setting. Input 3 as in **Aus/Ein**

Taster: Additional stop functionality.

SM3G



SM3G-ST09-H02
EAN-Number: 4260194732071

SENSOR for switching multiple groups

The **SIENNA® SM3G** sensor has three digital inputs which can be connected to a 2-gang or 3-gang switch (Blind, Shutter: Up, Down, Stop). Centralized switching functionality (Master-On, Master-Off) can also be implemented with **SM3G**.

The **SM3G** switches actuators which have consecutive group addresses (e.g. g = C switches actuators in groups C & D). The second group is switched with a time delay of 1s.

Input:

See **SM3**.

Operational mode for input 3 (sliding switch):

See **SM3**.

AM2 / AMX2



AM2-ST01-H01 / AMX2-ST05-H01
EAN-Number: 4260194730053 / 114

AKTOR for motor control

The **SIENNA® AM2** actuator can be directly mounted to a motor. **AM2** has relay-switched output for motors with current ratings up to 3A. The outputs are interlocked such that only one output can be active at any time. Run time can be set with **SIENNA® Professional** (default run time is 120s.).

Output:

L1, N, L2, N for connecting to motor; one relay each to switch L1, L2 (Up, Down) up to 5A. N is bridged to the neutral of the power supply.

Operational modes:

Auto: Motor runs to end position; stops if switch is reactivated.

0: Comfort switching for setting the slat angle of a sunblind / shutter

Man: Motor runs only when switch is activated.

SIENNA® AM2X actuator is similar to **AM2**, but with potential free outputs.

SAM2



SAM2-ST01-H01
EAN-Number: 4260194734020

SENSOR / ACTUATOR combination for motor control

SIENNA® SAM2 combines the **SM3** sensor and **AM2** actuator in a single module. **SAM2** has 2 inputs for a blind-control switch and 2 interlocked **outputs motors with current ratings up to 3A. Run time can be set with SIENNA® Professional** (default run time is 120s.).

Input:

Three flexible wires for connecting to a switch.

Output:

▲, N, ▼ for connecting to motor; one relay each to switch ▲, ▼ ((Up, Down) up to 5A. N is bridged to the neutral of the power supply

Operational modes:

0: Motor runs to end position; stops if switch is reactivated.

1: Comfort switching for setting the slat angle of a sunblind / shutter

2: Motor runs only when switch is activated.

Motor control & central switching

Controlling sunblinds

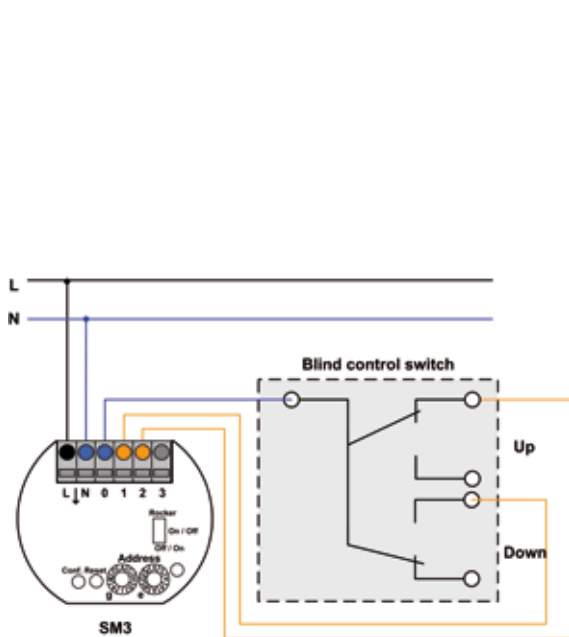

Master switch (g, 0);
also for timers and weather stations

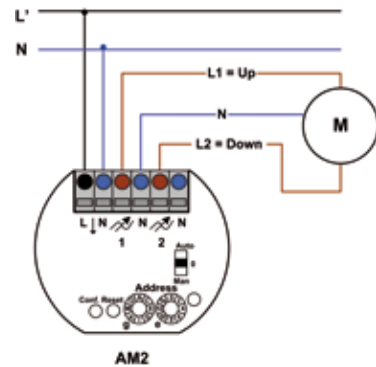

Actuator / Motor control

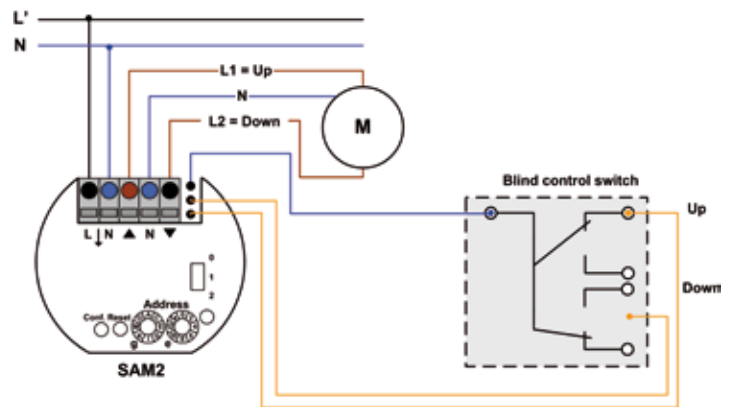

Control point with inputs / outputs

Panic switch / Master OFF (please refer to "Wiring plans" p. 20)

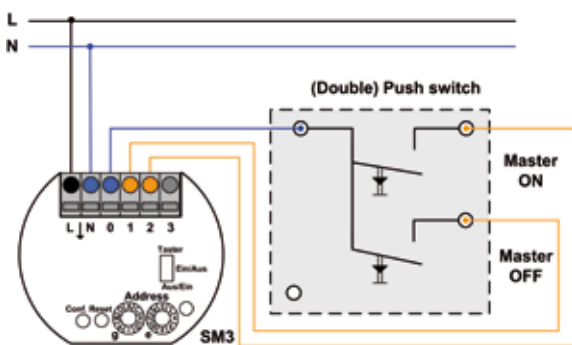

Address assignment: g, e = 0
Controls all elements with identical g.

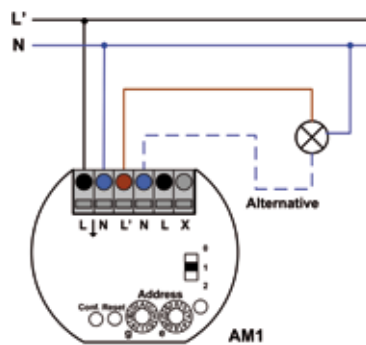

Address assignment: g, e = 1

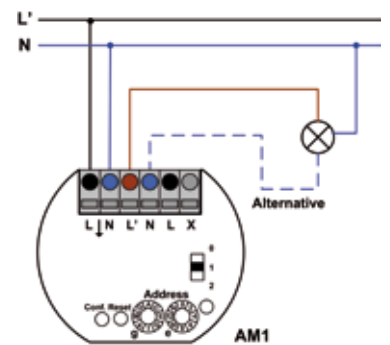

Address assignment: g, e = 2

AMDR



AMD-ST04-H02
EAN-Number: 4260194730084

DIM-ACTUATOR, Leading edge

The **SIENNA® AMDR** actuator is designed to dim and / or switch incandescent lamps and conventional transformers. The **SIENNA® AMDR** actuator has one triac-switched output for electrical devices up to 300W. Loads up to 150W are allowed when the actuator is used with universal electronic transformers (leading and trailing edge). In overload conditions, the actuator switches off automatically and can be activated only after a predefined cooling phase (60s.).

Output:

L', N for connecting to electrical device; One leading-edge output rated at 300W ($\cos \phi = 1$) for dimming L'. N is bridged to the neutral of the power supply.

Operational modes:

0 / 1: R, L loads up to 300W ($\cos \phi = 1$); 150W ($\cos \phi = 0,6$)

2: Universal electronic transformers upto 150W, Takes into account the min. load requirements for universal transformers; Dims in the range from 30% - 100%.

SAMDR



SAMDR-ST01-H01
EAN-Number: 4260194734037

SENSOR / DIM-ACTUATOR combination, Leading edge

The **SIENNA® SAMDR** module combines the **SM1L** sensor and **AMDR** actuator in a single module. **SAMDR** has a 230V input and a triac-switched output for electrical devices up to 300W. Loads up to 150W are allowed when the actuator is used with universal electronic transformers (leading and trailing edge). In overload conditions, the actuator switches off automatically and can be activated only after a predefined cooling phase (60s.).

Input:

One digital input (L, 1) with 230V / ~50Hz (Phase bridged to L'). Can also be used with switches that integrate a indicator lamp

Output:

See **SIENNA® AMDR**.

Operational modes:

See **SIENNA® AMDR**.

AMD10V



AMD10V-ST01-H01
EAN-Number: 4260194730091

DIM-ACTUATOR (1 - 10V)

The **SIENNA® AMD10V** actuator can be used with electronic ballasts or other devices with a 1-10V interface to switch and / or dim these devices. The **SIENNA® AMD10V** actuator has a current sink of max. 30 mA and can switch up to 6 electronic ballasts connected in parallel.

Output:

Relay putput L' for switching loads up to 10A.

N is bridged to the neutral of the power supply.

Output +, - is a 1-10V output for dimming the load. Output can have max. 30mA when operated with several loads connected in parallel.

AM1A / AMXA



AM1A-ST04-H01 / AMXA-ST04-H01
EAN-Number: 4260194730015 / 46

ACTUATOR for alternate switching

The **SIENNA® AM1A / AMXA** actuator can either be directly attached to an electrical device or flush-mounted behind a power outlet and is designed for alternate switching The actuator has two outputs with oppositely switched relays for electrical devices with current ratings up to 5A.

SIENNA® AM1A 230V output:

L1, N, L2, N to the devices / electrical circuits: L1 and L2 are oppositely switched outputs up to 5A.

The output terminals N are bridged to the neutral of the power supply

SIENNA® AMXA floating output:

X1, X, X2 are connected to the devices: X1 and X2 are oppositely switched outputs with an external potential (X) up to 5A

Dimming

Dimmer control

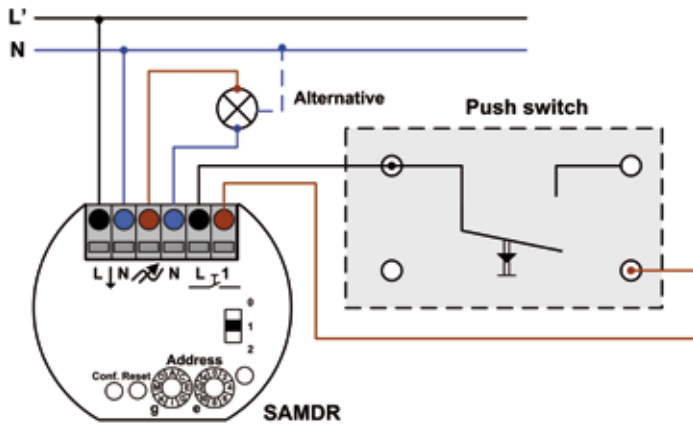
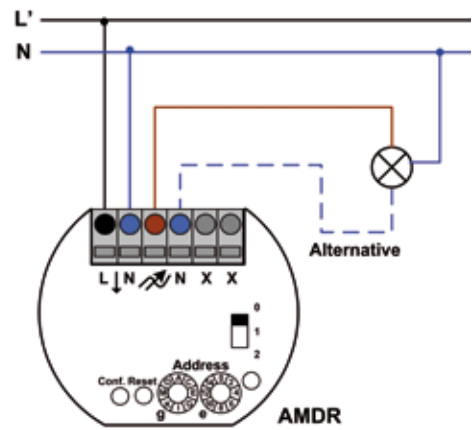
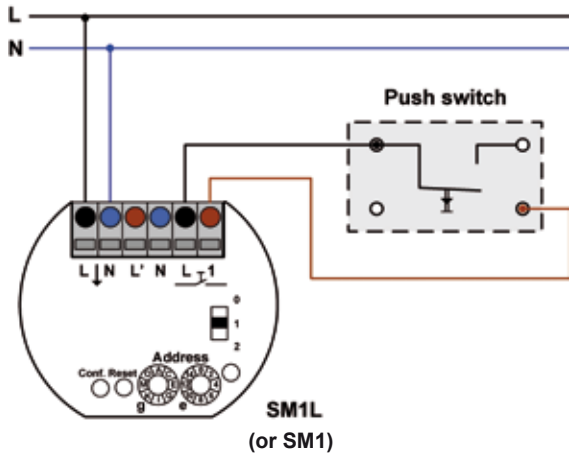

Regulating a motor (e.g. pump for a water fountain)

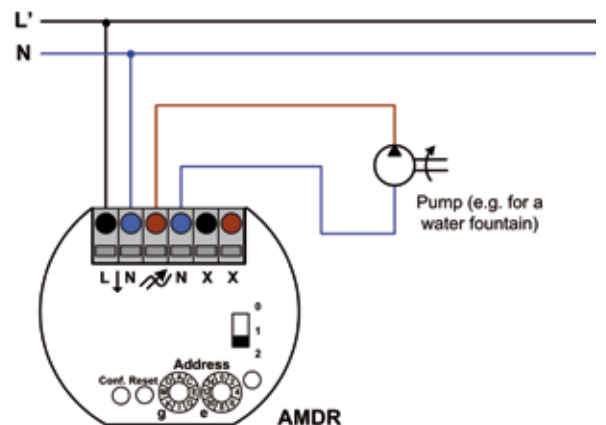
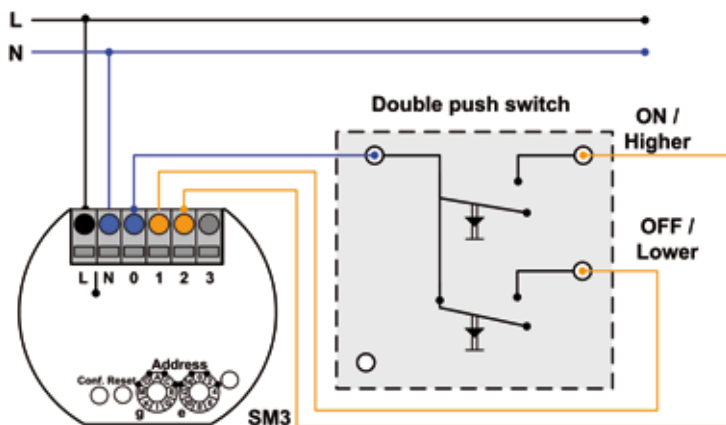

Please note that the pump needs to work together with a leading edge dimmer.

THERMOSTAT

SIENNA® SMTEMP room temperature controller with temperature sensor and continuous-action controller; compatible with front panels from Berker, Gira, Merten, Jung und Peha.

Model **SAMTEMP-ST02-H02** has additional switched outputs (floating).

Input:

Potentiometer for setting the temperature.

Output:

SIENNA® SAMTEMP-ST02-H02 with two switched outputs (2 oppositely switched potential free relays).

SMTEMP / SAMTEMP



SMTEMP-ST01-H02 / SAMTEMP-ST02-H02
EAN-Number: 4260194732088 / 4044

SIENNA® RFGS

Wireless gateway inc.. wireless remote for all SIENNA® actuators

SIENNA® RFGS is a gateway for mapping wireless channels to **SIENNA®** powerline devices.

- Plug-in module with RF-Receiver and **SIENNA®** Powerline output
- Compatible with all Easywave RF-transmitters e.g. remote control or door-/window contacts.
- 32 configurable RF-Channels.
- Configurable with a screwdriver.
- Includes a 5-Channel remote control for usage with all **SIENNA®** actuators.

Technical Specifications (Gateway):

| | |
|---------------------------------|--|
| Frequency:..... | 868,30 MHz |
| Modulation:..... | FSK |
| Range(RF):..... | Outdoors: ca. 100 m; indoors: ca. 30 m |
| RF-Protocol:..... | Easywave; compatible with all Easywave remotes (http://www.eldat.de) |
| Channel Assignment:..... | Maximum 32 RF-Channels |
| Power Supply:..... | 230V~/50 Hz, power consumption max. 1.5W |
| Standby Power Consumption:..... | < 0,5W |
| Operating Temperature:..... | -25°C to +70°C |
| Safety Compliance:..... | EN 300 220-1 V1.3.1 (2000-09), EN 300 220-3 V1.1.1 (2000-09) |



Technical Specifications (Remote):

| | |
|-----------------------------|---|
| RF properties:..... | See Gateway |
| RF-Channels:..... | 5 RF-Channels, with On / Up and Up / Down buttons |
| Power Supply:..... | 1 x 3V-Battery, CR2032 |
| Operating Temperature:..... | -20°C bis +60°C |
| Safety Compliance:..... | EN 300 220-1 V1.3.1 (2000-09), EN 300 220-3 V1.1.1 (2000-09) |



RFGS-ST01-H01
EAN-Number: 4260194736017

SIENNA® HOME

for Home Automation and Remote Access

SIENNA® Home is a Web-Server with an embedded application for controlling all SIENNA® devices

- The SIENNA® Home Controller is always on and can control SIENNA® devices without an attached PC. A PC with a web browser is required only while configuring the controller.
- Scenarios and Schedules can easily be configured using a browser.
- All components can be controlled and monitored remotely using a PC or a mobile phone with a web interface..



Technical Specifications:

| | |
|-----------------------------------|--|
| Processor: | RISC-CPU@400MHZ230V~/50Hz |
| Network Interface: | 1 x 10/100 Ethernet Port |
| USB Port: | 2 x USB.2.0 |
| Powerline Interface: | LonWorks Powerline |
| Memory: | SDRAM: 64 MB; FLASH: 64 MB |
| Console: | Ethernet (RJ45) with DHCP Server |
| GUI: | Browser (PC, TV, Mobile phone) |
| Operating System: | Linux |
| Network Properties: | DHCP client, HTTP server, VPN |
| Applications: | Home Automation Framework, OSGi Framework, JRE |

SRV-HOME-ST01-H01
EAN-Number: 4260194736000

SIENNA® Professional: for installation and configuration

SIENNA® Professional is a Windows program for installing and configuring all SIENNA® components and is designed for system integrators. The PC based configuration can be used together with or as an alternative to the screwdriver based configuration. This tool makes it very simple to change the configuration or to retrieve existing installations with a PC or a laptop.

The USB port of the PC is used to couple to the communication bus i.e. the powerline. Any nearby power outlet can be used to access the powerline. The coupling element PC/power plug is included with the software package.

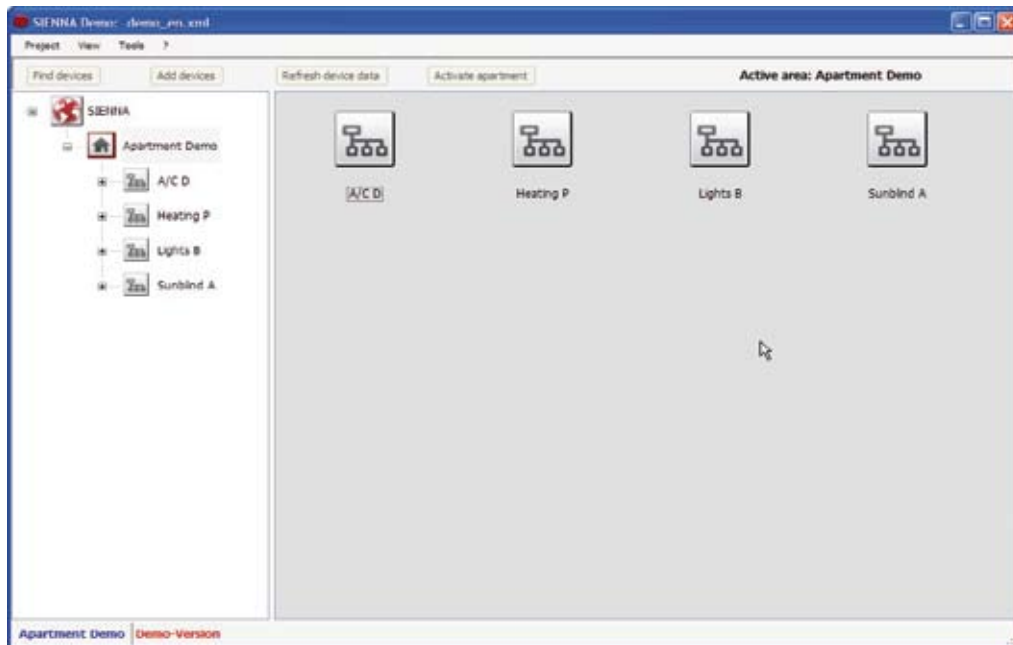

System requirements, Laptop/PC:

- Processor:**..... Intel® Pentium® Processor
- Operating System:**..... Windows XP Professional / Home, Vista (32-Bit), Windows 7 (32 Bit).
- Hard disk:**..... 20 MB available space on hard disk
- RAM:**..... 64 MB RAM
- Screen Resolution:**..... 1024 x 768
- Interface:**..... USB 1.1 or 2.0.

Technical Specifications (coupling element):

- Technology:**..... Powerline communication in the B/C-Band (5kb/s) compliant with FCC, CENELEC EN50065-1 and LONWORKS® protocol.
- Bus coupling:**..... Power plug, 230V~/50Hz.
- PC coupling:**..... USB 1.1 or 2.0.
- Operating Input Current:**..... Power supply/Power plug: 250 mA maximum @ 18VDC.
USB: 50 mA maximum @ 5VDC.
- Processor:**..... Neuron processor integrated in the Powerline Smart Transceiver PL 3120.
- Operating temperature:**..... -25°C to +70°C.
- Safety compliance:**..... CE, EN55022 Class B, EN55024, ETSI300 019-2-3 T3.2, TÜV EN60950.



SW-PROF-ST01-H02
EAN-Number: 4260194736048

| | |
|--|---|
| <p>DIN-G</p>  <p>DING-H01 EAN-Number: 4260194737007</p> | <p>DIN-Rail Housing</p> <p>DIN-rail housing for all SIENNA® flush-mounted modules.</p> <p>Housing corresponds to DIN 43 880, size 1. Simple and quick assembly by locking onto DIN-rails EN 60 715 TH 35. Base part with fixing towers. Top part with ventilation slots. Vertical and horizontal guides for additional PCBs. Locking lid for protecting the display and operating elements.</p> <p>Model: With perforations for cable feeds.</p> <p>Package includes: 1 base with locking clip, 1 top cover</p> |
|--|---|

Technical Specs. (**SIENNA®** flush-mounted modules):

- Technology:**..... Perilune communication in the Backbone (5Kb/s) compliant with FCC, CENELEC EN50065-1 and LONWORKS® - Protocol.
- Power Supply:**..... 230V~/50Hz, Power consumption 0.5W..1.5W via L, N connectors plus attached device.
- Processor:**..... Neuron-Processor integrated in Powerline Smart Transciever PL 3170.
- Connectors:**..... 0.08mm² - 1.5mm² for all connecting cables.
- Operating Temperature:**..... -25°C to +70°C.
- Voltage Surge Protection:**..... Varistor.
- Standby Power Consumption:**..... < 0,5W.
- Range:**..... 300m connection length over all 3 phases; up to 2km on a single Phase.*
- Safety Compliance:**..... CE, EN60669, EN50065-1.

*Differences in connection length can occur due to presence of other electrical elements (e.g. ground fault circuit interrupter).

Dimensions:

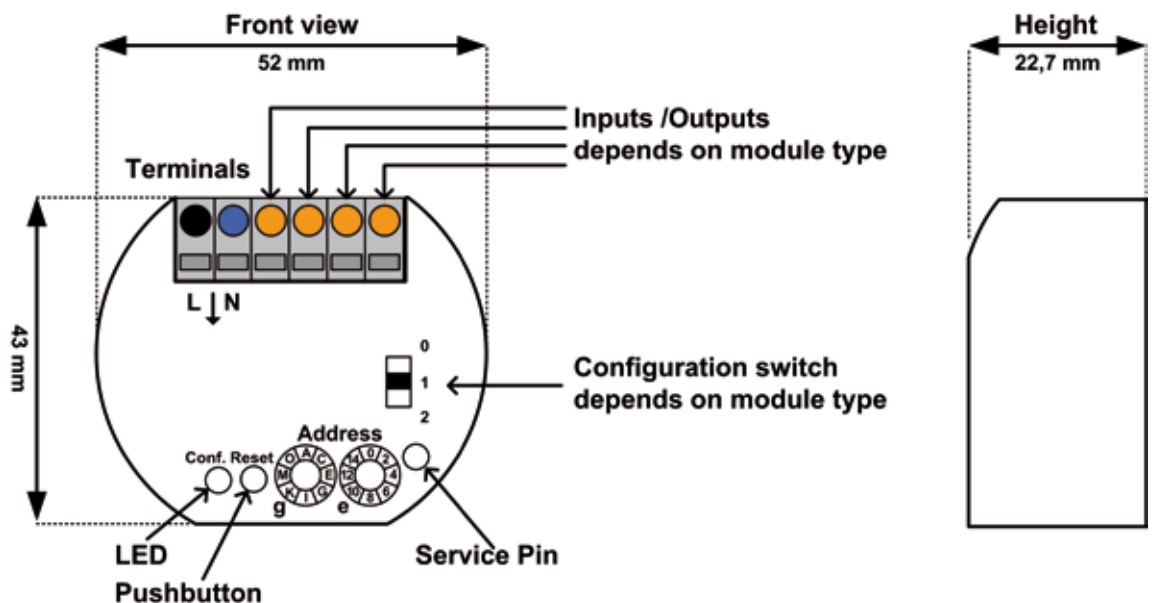

All **SIENNA[®]** elements have two rotary switches, each with 16 positions, for address assignment.

- The first rotary switch sets the group address g to an alphabetic value (A, B, ..., P).
- The second rotary switch sets the element address e to a numerical value (0, 1, ..., 15).
- Arbitrary many elements can have identical g and e : All elements with identical (g, e) switch simultaneously.

Group address g indicates a particular group

- E.g. all sunblinds have identical g , different e .

Element address e

- Sensors with $e = 0$ control all actuators with identical g regardless of e (e.g. centralized control of sunblinds).
- $e = 0$ is a master switch; e.g. sensor connected to wind detector has the address ($g, e = 0$): this sensor controls all sunblinds with identical g and arbitrary e .

Scheme: 3-Way switching

Arbitrary many sensors and actuators can have identical addresses. In this case each sensor controls all actuators. E.g.: Each of the 3 sensors switches 2 actuators:

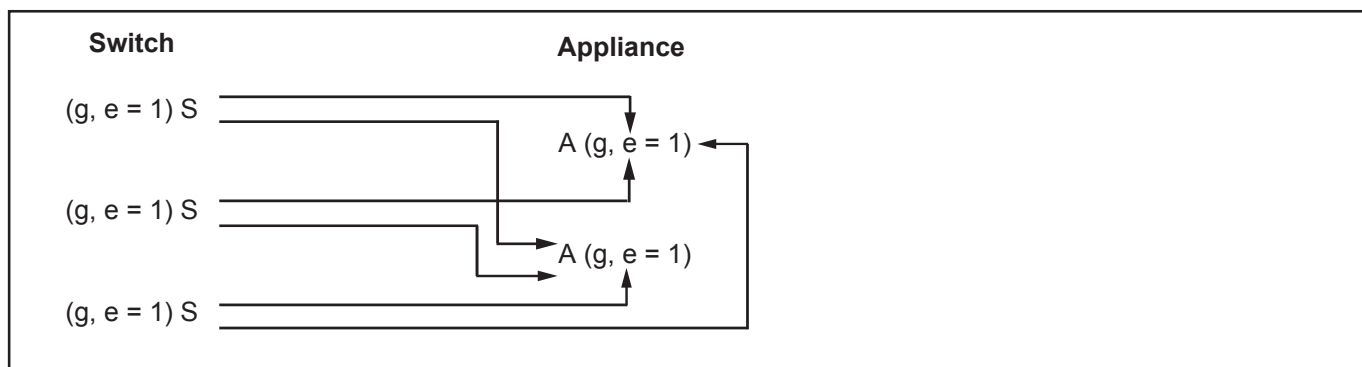

Scheme: Master Switch

The address $g, e = 0$ defines a sensor to be a master switch. This sensor controls all actuators with identical g .

Note: The address $e = 0$ defines the master switch to be a On / Off switch regardless of the position of the sliding switch. This implies that for a push switch, one position is defined as "ON" and the other as "OFF".

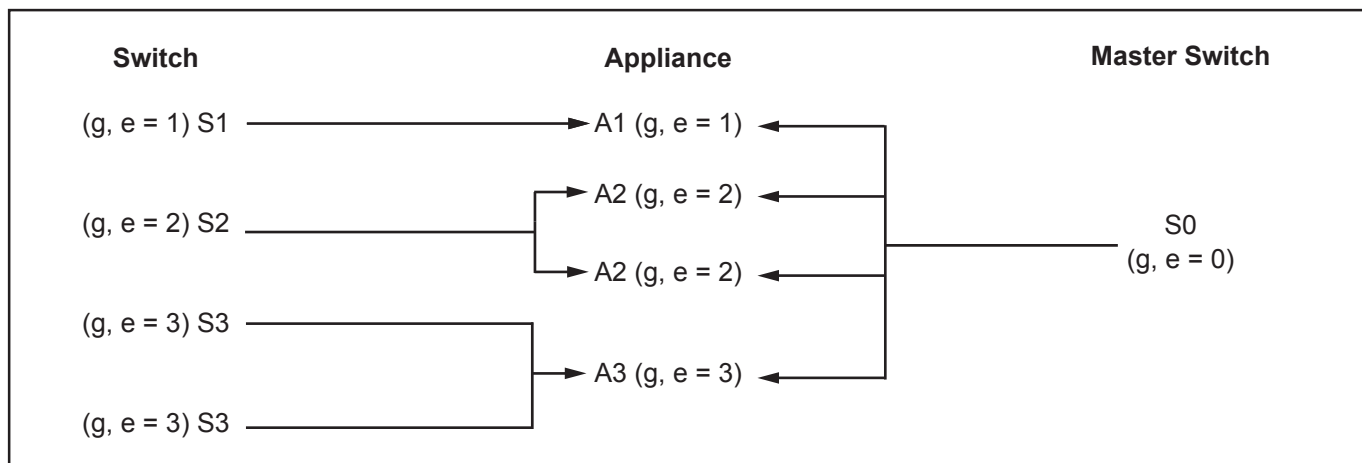

1. Disable / Enable exhaust fan(s) via window contact

Installing a fireplace in an apartment is often associated with implementation of additional safety measures e.g. one needs to ensure that an adequate supply of fresh air is always available. In most situations this implies that the exhaust fans in the apartment can only be operated when the windows are open. **SIENNA®** offers a solution which can be retrofitted in existing homes. A **SIENNA®** sensor attached to a magnetic contact at the window and actuators attached to the exhaust fans - this makes the exhaust fans operational only when the window is open.

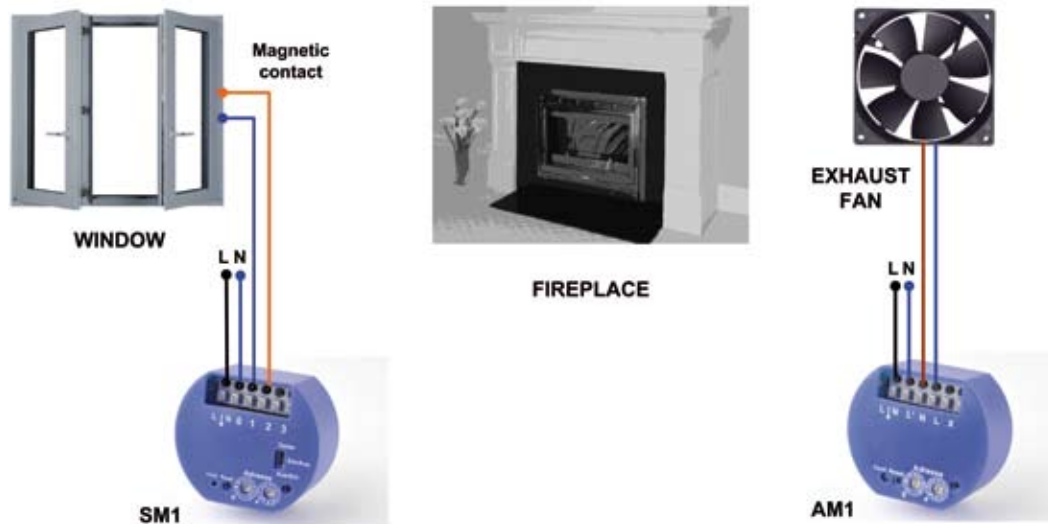

- **SIENNA® SM1** with 5V input connected to window contact.
- **SIENNA® AM1** disconnects power supply to exhaust fan(s).

2. Disable / Enable exhaust fans via boiler unit

Similar to fireplaces the simultaneous operation of a boiler unit and exhaust fans in an apartment can lead to dangerous situations. E.g. the exhaust fans drawing in the exhaust fumes from the boiler into the apartment can result in a life threatening situation. **SIENNA®** offers a solution which can be retrofitted in existing homes. A **SIENNA®** sensor connected to the output of the boiler and actuators attached to the exhaust fans - this disables the exhaust fans until the boiler is turned on.

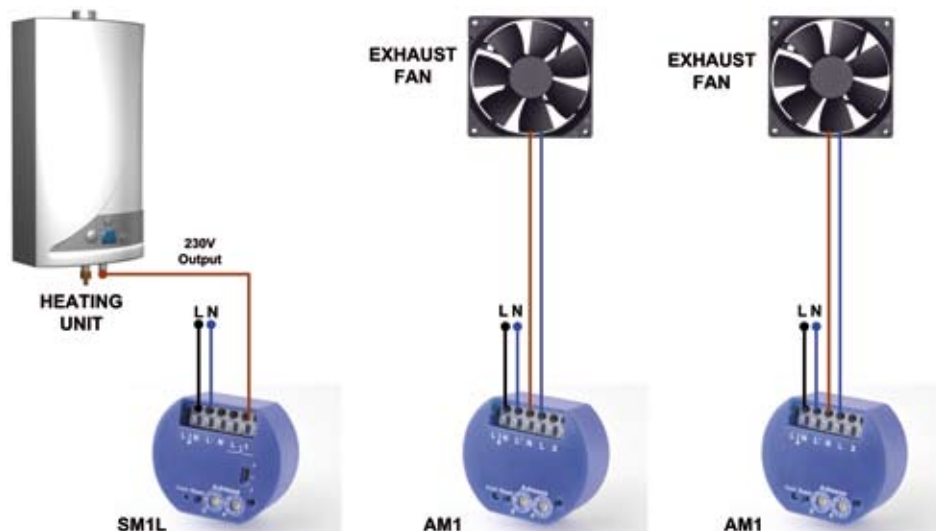

- **SIENNA® SM1L** connected to 230V output of boiler unit.
- **SIENNA® AM1** disconnects power supply to exhaust fan(s).

3. Temperature control: Floor heating

SIENNA[®] offers a solution for regulating the temperature in each room separately--a solution that can be retrofitted in existing buildings. SIENNA[®] sensors with conventional thermostats are installed at an appropriate place in each room and SIENNA[®] actuators are connected to the appropriate heating valves. Each thermostat can now control the corresponding heating valve and regulate the floor heating individually in each room. A measure of extra comfort that not only saves on heating bills but also contributes towards a greener world.



- SIENNA[®] SM1L connected to thermostat output..
- SIENNA[®] AM1 switches heating valve.

4. Panic switch/ Master-OFF

SIENNA[®] allows one to easily retrofit a panic switch in existing homes. SIENNA[®] sensors connected to the existing light switches and one central sensor is sufficient to activate the panic switch feature. If necessary the shades / blinds can also be raised when the lights are switched on. With SIENNA[®] and with minimum effort one can easily enhance security and sleep peacefully at night.

- Master switch (SIENNA[®] SM3) Push switch connected to input 1 switches ON all actuators (Panic switch).
- Master switch (SIENNA[®] SM3) Push switch connected to input 2 switches OFF all actuators (Master-OFF).

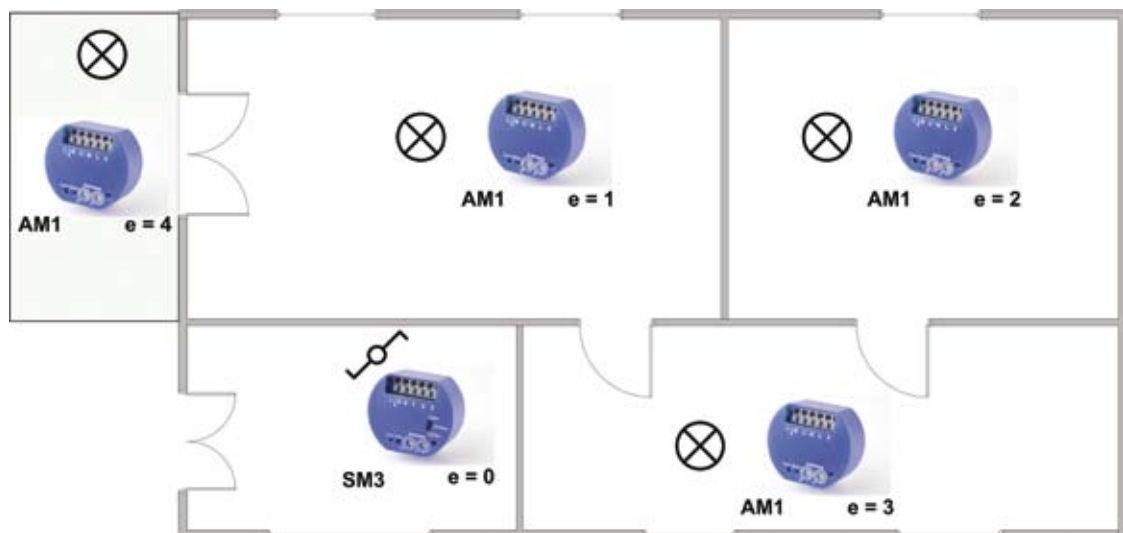

- SIENNA[®] SM3 with a push switch connected to input 1 (Address = 0).
- SIENNA[®] SM3 with Master_OFF switch connected to input 2.
- SIENNA[®] AM1 / AM2L actuators with address = 1, 2, 3, 4, etc.. are switched ON via the panic switch.

5. Hot water supply

New and old homes both waste large amounts of energy when hot water is supplied to the whole house. In order for the hot water to be readily available throughout the house, a circulation pump distributes hot water through pipes either continuously or on a timed basis (e.g. 14 hours a day). This results in a significant, and completely unnecessary, waste of energy. It is possible, however, to save about 30% of the hot water bill by starting the circulation pump only on demand, i.e. at the moment hot water is needed at a certain tap

SIENNA® offers exactly this solution which can be retrofitted in existing homes. **SIENNA®** sensors, connected to standard switches near the hot water taps, start the circulation pump only on demand. A **SIENNA®** actuator with a timer function lets the circulation pump run just long enough to provide hot water at all the taps--typically less than a minute. Approx. 30-40s after pushing the switch, hot water is available at the taps -- an easy way to save money and be eco friendly at the same time.

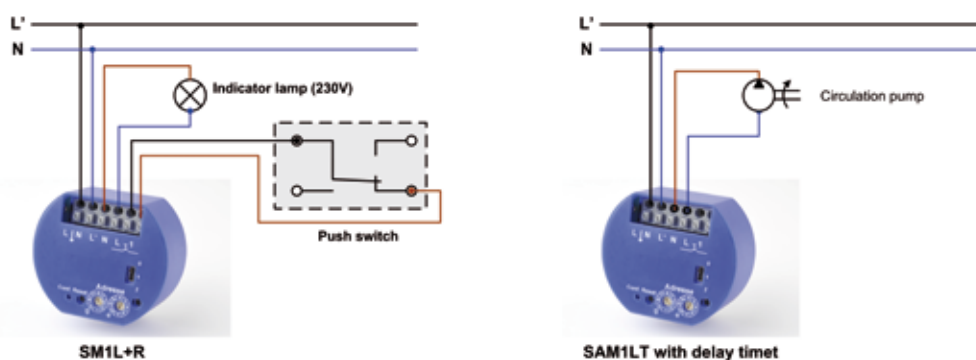

- **SIENNA® SM1L+R** connected to wall-switch in the bathroom / kitchen -- the indicator lamp is on when the circulation pump is on.
- **SIENNA® SAM1LT** to control the circulation pump.

6. Motion detectors and indoor lighting

In the 70s motion detectors connected to the outdoor / garden lights were a standard way of preventing intruders from breaking in to empty homes. Nowadays this offers minimal protection against intruders and advanced features such as presence simulation are necessary to effectively prevent break-ins. But how does one retrofit a presence simulation mechanism in an existing home without expensive remodelling?

SIENNA® offers a solution which can easily be retrofitted in existing homes. All you need is a **SIENNA®** sensor connected to the motion detector triggering the outdoor lighting and a **SIENNA®** actuator connected to a lamp inside the house. As soon as the motion detector is triggered, it switches on a light inside the house -- an ingeniously simple way of simulating presence in the home.

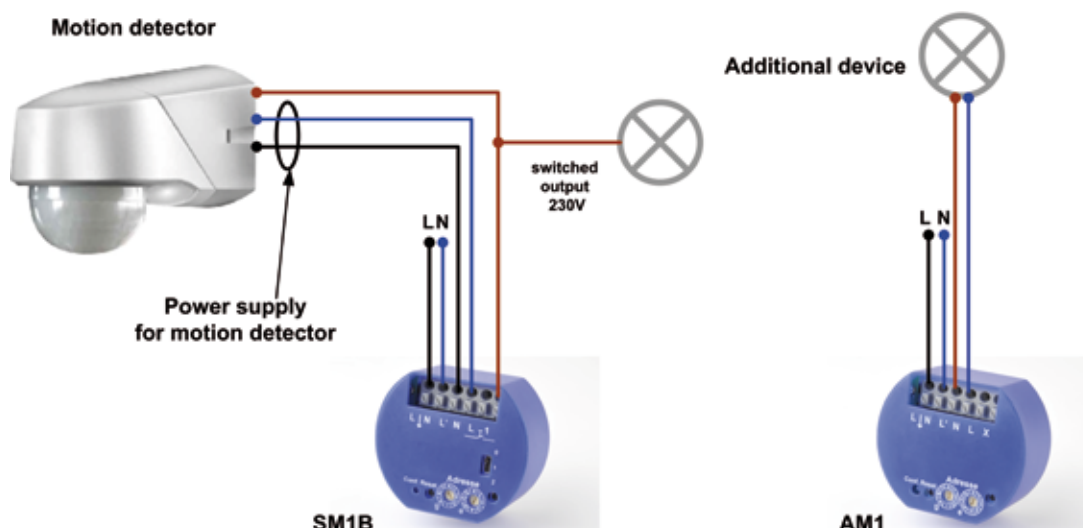

- **SIENNA® SM1B** or **SM1L** connected to the output of the motion /occupancy detector.
- **SIENNA® AM1** connected to an indoor light.

7. Room temperature control via a mobile phone

SIENNA[®] Home offers the possibility to control and monitor the heating, lighting etc. at home from anywhere and at anytime --- and this can be retrofitted in all existing homes. The SIENNA[®] Home Server can be used to remotely access the electrical devices at home via the internet. E.g., the room temperature can be remotely controlled using a mobile phone so that one comes back from work to a warm and cosy home without wasting energy throughout the day--a feature that is convenient and at the same time contributes towards a greener world.

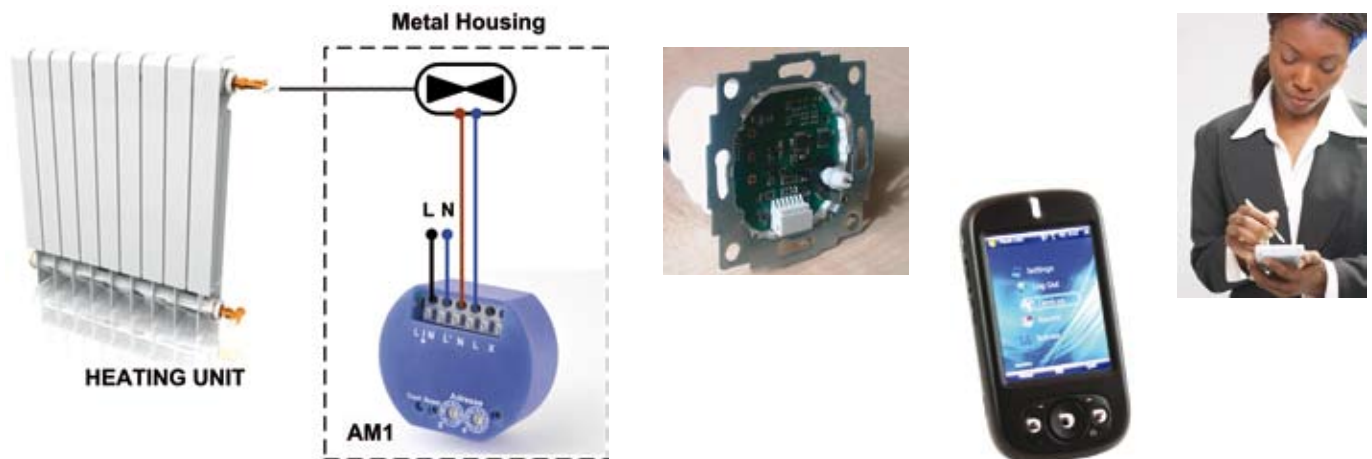

- **SIENNA[®] SMTEMP** functions as the thermostat for regulating room temperature.
- **SIENNA[®] AM1** switches the heating valve.
- **SIENNA[®] Home** for remote access

8. Scenes and Schedules

Scenes and schedules that control the lighting / heating / motorized blinds or other electrical appliances in a home provide comfort and convenience, help save energy and are an important part of an enhanced lifestyle. In homes using conventional electrical wiring it can be a real challenge if not impossible to implement these additional features without expensive remodelling.

SIENNA[®] offers a very simple solution - a solution that can be retrofitted in all existing homes.

The **SIENNA[®] Home Server** makes it possible to integrate any **SIENNA[®]** actuator into a scene. These scenes can then be run individually or as part of a schedule via the **SIENNA[®] Home Server**. The homeowner can create individual scenes / schedules that turn lights on and off, adjust lighting levels or open and close the blinds to create the ideal mood for television viewing, entertaining around the dinner table or outdoor living. Another advantage of living in a smart home!



- **SIENNA[®] Home** for defining and running scenes and schedules.
- **SIENNA[®]** modules for controlling the devices.

- **How does SIENNA® work?**

SIENNA® sensors and actuators use the 230V powerline as a communication bus. The components can communicate over all 3 phases without any phase couplers or other central units. Any sensor can control any actuator within a building independent of the actual electrical wiring. This combines the flexibility of wireless system with the reliability of a wired system.

- **What is the range of the SIENNA® components?**

The range is typically 300m cable length between the sensor and actuator independent of the actual phase. The components do not require additional phase couplers or frequency filters. A three-phase current cable (typically connecting the electricity meter and power distributor or the connection to the cooking range) is sufficient for the phase coupling. In cases where the sensor and actuator are on the same phase then the range extends upto approx. 2 km.

- **Why does SIENNA® not require phase couplers?**

SIENNA® components communicate via the powerline and this communication works over all 3 phases without the use of additional phase couplers. A three-phase current cable (typically connecting the electricity meter and power distributor or the connection to the cooking range) is sufficient for the phase coupling.

- **Why does SIENNA® not require frequency filters?**

During installation the **SIENNA®** components generate a domain (or building) address via a patented process. As a result neighboring buildings are logically separated from each other preventing any interference

- **How many SIENNA® nodes can you install in a single building?**

Up to 200 SIENNA® nodes can be installed in a single building. In case the no. of nodes is greater than 200, a slight delay may be observed during execution of switching commands.

- **Is SIENNA® compatible with other bus systems?**

SIENNA® uses the LON Standard and is compatible with other LonWorks based systems. Echelon's LonWorks is a ISO/IEC- and ANSI-compliant platform that enables some of the world's most advanced control and energy management applications. Normally LonWorks is used for commercial buildings and for big projects e.g. Munich Airport, the Reichstag in Berlin, the new trade fair center in Stuttgart. etc. **SIENNA®** is the first system that offers LonWorks based products for residential buildings.

Troubleshooting

- **An actuator does not respond to commands from the sensor.**

In most cases the addresses (rotary switches) are not identical.

Solution:

The addresses can be changed / corrected via the rotary switches. No reset is necessary !

- **A sensor with a 230V input does not switch reliably.**

The sensor has an high input resistance connected to the 230V input "1". For cable lengths > 10m between the switch and the input, it may occur that the voltage at the connecting wire is not completely reduced to ground-- this results in the sensor not responding correctly.

Solution:

A load module connected to the sensor between the connecting wire (Input "1") and ground reduces the voltage at the input so that the sensor can function correctly.

- **The motors attached to the motor-actuators do not run smoothly.**

The sensors used for motor control have low-voltage inputs and they can only be connected to potential-free switching elements. Outputs (e.g. timers) that are not potential-free have to be made potential-free (e.g. by using a interposing relay). If the 230V output is directly connected to the sensor inputs, the sensor will see a zero-crossing every 10 msec. and will try to start and stop the motor with the mains frequency.

Solution:

Connect the sensor inputs to potential-free switching elements.

- **The actuator and the sensor do not communicate with each other even though they have identical addresses.**

The **SIENNA®** modules generate a domain / area address during the installation process (see section on "Installation" in the user manual) Different domain addresses logically separate neighboring buildings / areas from one another. If the modules are configured in a sequence and not all together, different domain addresses are generated and the modules do not communicate with each other.

Solution:

Reset all modules by using the RESET button and then configure all modules in a single installation process (see section on "Installation" in the user manual).

Secyourit GmbH

THE HOME CONTROL COMPANY

Secyourit GmbH
Auenstr. 100
80469 Munich
Germany

January 2010

Tel.: +49 89 384 66 481 | Fax: +49 89 724 300 99 | Email: info@secyourit.com | Web: www.secyourit.com