

SIENNA® SM2+ Instruction Manual

Sensor with 3 inputs (internal 5V)

Connectors

All modules are connected to L and N of the power line (230V/50Hz) as shown in the figure.

The sensor is connected to a double switch or to two single switches as follows:

- 0: common ground connection,
- 1: switch 1, internal 5V contact,
- 2: switch 2, internal 5V contact,
- 3: switch 2, internal 5V contact.

SM2+ uses 3 addresses (g, e), (g, e+1) and (g, e+2)!

The sliding switch is used to choose between push (Push), normally open (On/Off) or normally closed (Off/On) contacts.

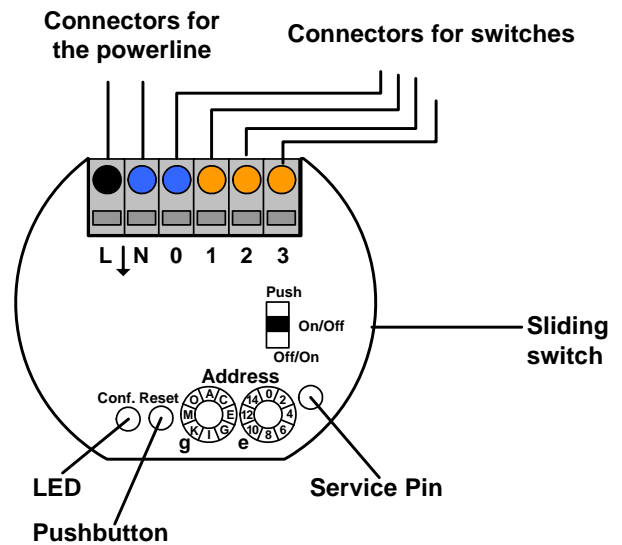

Address Assignment

The **SIENNA®** elements have two rotary switches for address assignment. Each switch has 16 valid positions.

- The first rotary switch sets the group address **g** with alphabetic values (A, B, ..., P).
- The second rotary switch sets the element address **e** with numerical values (0, 1, ..., 15).
- Arbitrarily many elements can have identical **g** and **e**.
- All elements with identical (**g**, **e**) switch simultaneously.
- **Input 1 addresses actuators with identical (g, e). Input 2 addresses actuators with (g, e+1). Input 3 addresses actuators with (g, e+2).**

Group address **g** defines a specific group:

- E.g. All sun blinds have the same **g** but different **e**.

Element address **e**:

- Sensors with **e = 0** control all actors with identical **g** regardless of **e**.
- **e = 0**: Master switch; E.g. Wind detector (**e = 0**) draws back all sun blinds with identical **g** and arbitrary **e**.

Address assignments can be changed either when the element has power or is disconnected from the powerline.

List of configured devices and their addresses

Please enter all configured devices and their respective addresses in the following table and keep it in a safe place (e.g. Fuse box). This will simplify future extensions and/or changes in the device configurations.

	Module type / Serial no.	g	e	Room	Function
1					
2					
3					
4					
5					
6					
7					
8					

Installation

Initial installation

SIENNA® elements are delivered in an unconfigured state: The following procedure is required during the initial installation of **SIENNA®** elements in a home (= Domain):

- Disconnect the mains power.
- Use the rotary switches to assign addresses to all elements (addresses can be changed when the element is connected to power) und connect all the elements.
- For connection of the wires to the terminal blocks, remove 10mm of the insulation from the wire ends.
- Switch on the mains power:
LED blinks on all the unconfigured elements.
- Choose an arbitrary unconfigured sensor and change the switch position 10 times within a period of 5 seconds. This results in a new domain being generated. Please note that this sensor should have a switch connected to it.
- After a further 5 seconds all unconfigured elements will be integrated in the new domain and are fully functional:
LED stops blinking on the configured elements.

Extending an installation

The following procedure is required when extending the initial installation with additional **SIENNA®** elements.

- Disconnect the power.
- Use the rotary switches to assign addresses to the new elements (addresses can be changed when the element is connected to power) and connect the new elements.
- Switch on the mains power:
LED blinks on all the unconfigured elements.
- Choose any previously installed sensor that is configured / functional and change the switch position 10 times within a period of 5 seconds. This sensor then assigns its domain to the new elements:
LED stops blinking on the configured elements.

Resetting to factory default

Reset button: Sets all values to the factory default.

- Should be activated with a pointed device e.g. ballpoint pen. Reset button must remain activated for at least 5 seconds when the element is connected to power
- LED switches on and blinks after 5 seconds: Device values reset to factory default.

Important Notice

The module is connected to the 230V power lines and the configuration switches should be touched only with insulated tools, e.g. an insulated screwdriver.

Product name: SM2-ST07-H02
EAN number: 4260194732033